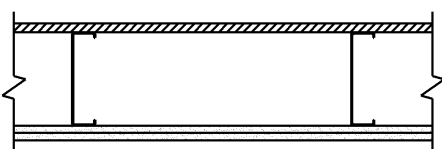
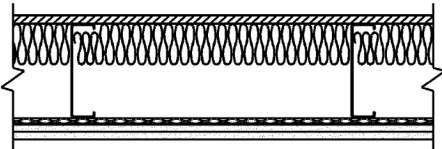
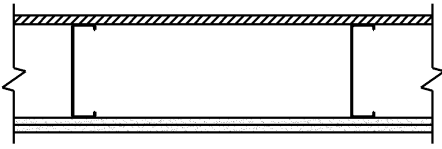

Floor/Ceiling Assemblies - Steel Framing

1 Hour	Design #	GA File #	STC - N/A	IIC - N/A
	UL L524	FC 4502	Sound Test # N/A	Test # N/A
 <p style="text-align: center; margin-top: 10px;"> Link to .PDF file Link to .DWG file Link to .DWG/Text file </p>	<p>Base layer 1/2" (12.7 mm) Fire-Shield C Gypsum Board applied at right angles to channel shaped, minimum 7" deep, 18 gage steel joists 24" o.c. with 1" type S-12 drywall screws 8" o.c. at ends and 12" o.c. at intermediate joists. Face layer 1/2" Fire-Shield C Gypsum Board applied at right angles to joists with 1-1/2" Type G Screws at end joints between joists and 1-5/8" Type S-12 drywall screws 12" o.c. at intermediate joists. Joints offset from base layer joints. Steel joists supporting 5/8" T&G plywood floor applied at right angles to joists with 1-15/16" #6 S-12 screws 6" o.c. at floor perimeter and end joints and 10" o.c. at intermediate joists.</p>			

1 Hour	Design #	GA File #	STC - N/A	IIC - N/A
	UL L580	N/A	Sound Test # N/A	Test # N/A
 <p style="text-align: center; margin-top: 10px;"> Link to .PDF file Link to .DWG file Link to .DWG/Text file </p>	<p>Base Layer 1/2" (12.7 mm) Fire-Shield C Gypsum Board applied at right angles to resilient furring channels with 1" Type S drywall screws 6" o.c. along the edges placed 1" back on either side of end joints and 12" o.c. in the field. Resilient furring channels applied at right angles to 10" channel shaped steel JoistRite joists and spaced 16" o.c. with 5/8" #10 Type S screws to steel joists 24" o.c. Face layer 1/2" Fire-Shield C Gypsum Board applied at right angles to channels through base layer with 1-1/4" Type S drywall Screws 6" o.c. along the edges and 12" o.c. in the field. Joints offset 16" from base layer joints. Steel joists supporting 3/4" T&G plywood floor applied at right angle to joists with 1-7/16" #10 wafer head winged plywood screws 6" o.c. along the edges and 12" o.c. in the field. 4" mineral fiber insulation friction fit between joists to underside of plywood.</p>			

1 Hour	Design #	GA File #	STC - N/A	IIC - N/A
	FM FC-172	FC 4490	Sound Test # N/A	Test # N/A
 <p style="text-align: center; margin-top: 10px;"> Link to .PDF file Link to .DWG file Link to .DWG/Text file </p>	<p>Base Layer 5/8" (15.9 mm) Fire-Shield Gypsum Board applied at right angles to channel shaped, steel joists 24" o.c. with 1-1/4" type S drywall screws 24" o.c. Face layer 5/8" Fire-Shield Gypsum Board applied at right angles to joists with 1-7/8" Type S drywall Screws 12" o.c. at joints and intermediate joists and 1-1/2" Type G screw 12" o.c. placed 2" back on either side of end joints. Joints offset 24" from base layer joints. Wood joists supporting 1/2" wood structural panels applied at right angle to trusses with 8d nails. Ceiling provides one hour fire resistance protection for trusses.</p>			

Floor/Ceiling Assemblies - Steel Framing

1 Hour	Design #	GA File #	STC - N/A	IIC - N/A
	UL L565	FC 4515	Sound Test # N/A	Test # N/A

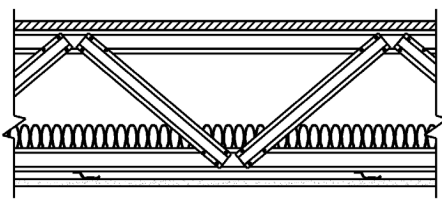

[Link to .PDF file](#)
[Link to .DWG file](#)
[Link to .DWG/Text file](#)

5/8" (15.9 mm) Fire-Shield C Gypsum Board applied at right angles to resilient furring channels 12" o.c. when insulation is used and 16" o.c. without insulation. Gypsum board attached with 1-1/8" type S drywall screws 12" o.c. Gypsum board end joints attached with screws 12" o.c. to additional pieces of channel 60" long located 3" back on either side of end joints. Resilient furring channels applied at right angles to light gage steel trusses spaced 48" o.c. with 1/2" Type S-12 screws. Steel trusses supporting 23/32" wood structural panels applied at right angle to trusses with construction adhesive and mechanical fasteners 12" o.c. and 15/32" wood structural panel underlayment applied at right angles to trusses with mechanical fasteners 12" o.c. Joints staggered between underlayment and subfloor.

1.5 Hour	Design #	GA File #	STC - N/A	IIC - N/A
	UL L527		Sound Test # N/A	Test # N/A

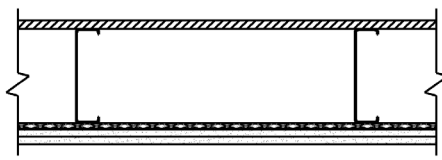

[Link to .PDF file](#)
[Link to .DWG file](#)
[Link to .DWG/Text file](#)

Base Layer 5/8" (15.9 mm) Fire-Shield C Gypsum Board applied at right angles to resilient furring channels with 1" Type S screws 24" o.c. Resilient furring channels applied at right angles to channel shaped steel joists and spaced 16" o.c. with 1/2" Type S-12 screws to steel joists 24" o.c. Face layer 5/8" Fire-Shield C Gypsum Board applied at right angles to channels through base layer with 1-5/8" Type S drywall Screws 12" o.c. Edge joints offset 16" from base layer joints. Butt joints of face layer to occur between resilient channels with 1-1/2" type G screws spaced 8" o.c. attached to base layer. Steel joists supporting 3/4" T&G plywood floor applied at right angle to joists

2 Hour	Design #	GA File #	STC - N/A	IIC - N/A
	UL L556	FC 4750	Sound Test # N/A	Test # N/A

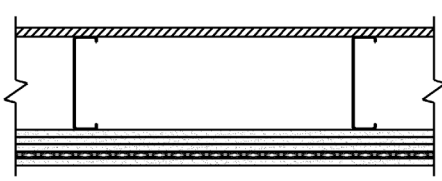

[Link to .PDF file](#)
[Link to .DWG file](#)
[Link to .DWG/Text file](#)

Base Layer 5/8" (15.9 mm) Fire-Shield Gypsum Board applied at right angles to 8" steel joists 24" o.c. with 1-1/4" Type S-12 drywall screws 12" oc. Second layer 5/8" Fire-Shield Gypsum Board applied at right angles to joists with 2" Type S-12 drywall Screws 12" o.c. Joints staggered 24" from base layer. Third layer 5/8" Fire-Shield Gypsum Board applied at right angles to joists with 2-1/2" Type S-12 drywall Screws 12" o.c. Joints staggered 12" from second layer. Rigid furring channels applied at right angles to joists over third layer with two 2-1/2" Type S-12 drywall Screws at each joist. Face layer 5/8" Fire-Shield Gypsum Board applied at right angles to furring channels with 1-1/8" Type S drywall Screws 12" o.c. Steel joists supporting 3/4" T&G plywood floor applied at right angle to joists with #10x1-5/8" screws 12" o.c. along joists.